

# Duct CO2 Transmitter

Part # 105901

## Installation Instructions

### Introduction

The CO2 transmitter uses Infrared Technology to monitor CO2 levels and outputs a linear 4-20 mA or 0-5/0-10 Vdc signal. Features include a back-lit LCD and user menu for easy set up and a control relay with user selectable setpoint.

### \*\*\*Before Installation\*\*\*

Read these instructions carefully before installing and commissioning the CO2 transmitter. Failure to follow these instructions may result in product damage. Do not use in an explosive or hazardous environment, with combustible or flammable gases, or as a safety or emergency stop device or in any other application where failure of the product could result in personal injury. Take electrostatic discharge precautions during installation and do not exceed the device specifications, as listed on page 2. Do not mount the transmitter in the same electrical box with line voltage devices. Use 22 AWG shielded wiring for all connections and do not locate the device wires in the same conduit with wiring used to supply inductive loads such as motors. Make all connections in accordance with national and local codes.

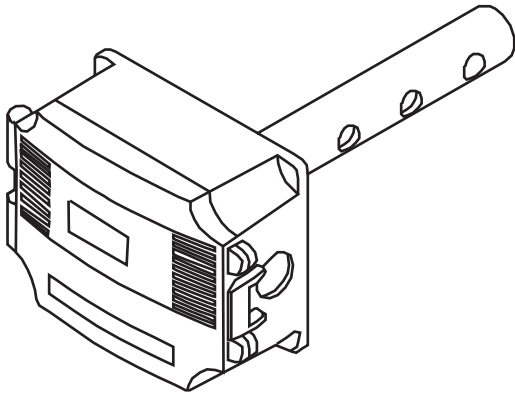

### Mounting

The duct CO2 transmitter installs directly into any return air duct with a minimum of width/diameter of 8" (21 cm). Select an installation area in the middle of the duct wall. To achieve the best reading, do not place in an area where air stratification may be present. **Mount the sensor at least 5' (1.5 m) in either direction from elbows, dampers, filters or other duct restrictions. Avoid areas where the detector is exposed to vibrations or rapid temperature changes.**

Once a suitable spot is selected, drill a 1.125" - 1.25" (29 -32 mm) hole for the aspiration probe.

Slide the aspiration probe in the drilled hole so that the inlet holes on the probe point directly into the airstream until the enclosure is flush against the duct. The airflow direction is not important as there are not specific inlet/outlet holes in the aspiration probe. Secure the enclosure to the duct with (4) #10 x 1" (25 mm) self tapping screws (Not provided). Tighten screws until the enclosure is tight against the duct and that there is no movement of the enclosure. See Figure 1.

A foam gasket is provided on the back of the enclosure that provides a tight seal against any air leaks.

Using a Phillips screwdriver, remove the (2) security screws, as shown in figure 2. Set aside for re-installing after wiring and set up.

Using thumb, pull cover latch slightly outward until cover tab dis-engages and swing open cover. See Figure 3.

A 7/8" (21 mm) hole is provided for connection of either 0.5" (12.77mm) EMT or a cable gland style connector. Insert the EMT or connector through the hole and securely fasten using a locknut. See Figure 4. Use the included foam plug to prevent air from entering the enclosure through the EMT and causing an incorrect reading See Figure 5. **Special care must be taken not to damage any internal components during installation.**

Make wire connections as per the "Wiring" illustrations on Page 2. Once wiring and set up are complete, close cover and push firmly until cover latch engages. Re-install and tighten the (2) security screws using a Phillips screwdriver.

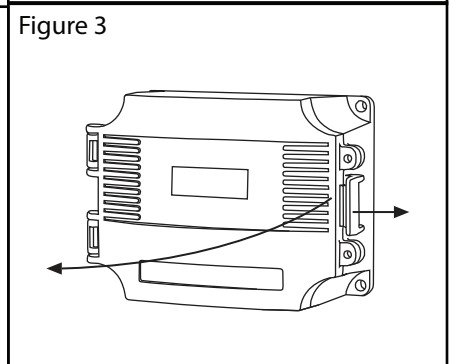
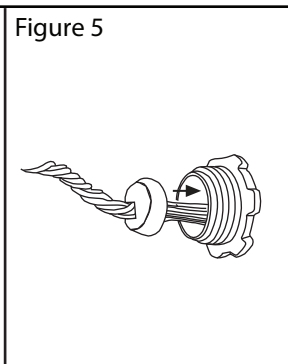
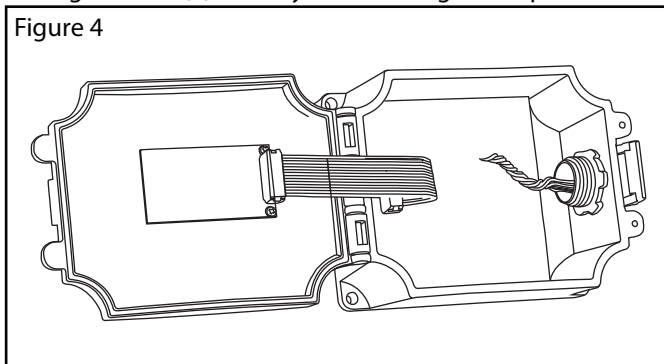
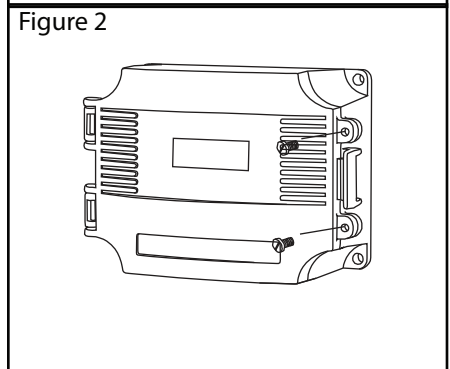
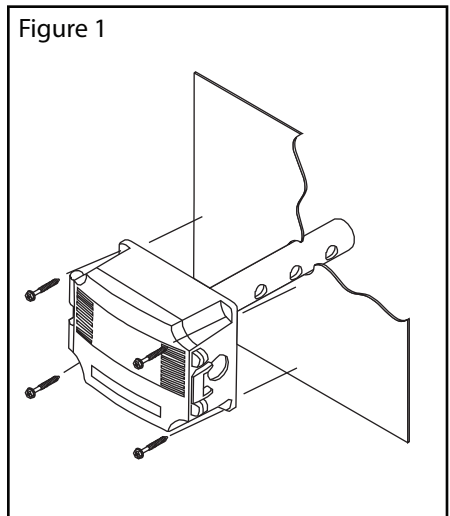

## Wiring

- Deactivate the 24 Vac/dc power supply until all connections are made to the device to prevent electrical shock or equipment damage. **Do not wire the device with power applied as accidental arcing may damage the product and void the warranty.**
- Select desired signal output type by sliding the Output switch into desired position as shown in Figure 5. The factory default is "VOLT" and set to 0-10 Vdc. It may be changed to 0-5 Vdc during program set up. The "mA" setting provides a 4-20mA output.
- This is a 3-wire sourcing device. Connect the plus dc or the ac voltage hot side to the PWR terminal. The supply common is connected to the COM terminal. The device is reverse voltage protected and will not operate if connected backwards. It has a half-wave power supply so the supply common is the same as the signal common. Several devices may be connected to one power supply and the output signals all share the same common. Use caution when grounding the secondary of a transformer or when wiring multiple devices to ensure the ground point is the same on all devices and the controller. See Figure 8.
- The analog output is available on the CO2 terminal as shown in Figure 8. This signal is switch selectable for either voltage or 4-20 mA active output. In voltage mode, the output is selectable for either 0-5 or 0-10 Vdc via the menu (the factory default is 0-5 Vdc). The current output operates in the active mode and does not require a loop power supply (the signal current is generated by the transmitter and must not be connected to a powered input or device damage will result). Check the controller Analog Input to determine the proper connection before applying power. Both current and voltage signals are referenced to the COM terminal. The analog output signal is typically connected directly to the Building Automation System (B.A.S.) and used as a control parameter or for logging purposes.
- The relay output is on the N.O. RELAY terminals as shown in Figure 7. The relay output is completely isolated and has a Normally Open (NO) signal. This signal can be used to directly control an alarm or ventilation fan. See specifications below for switch rating.

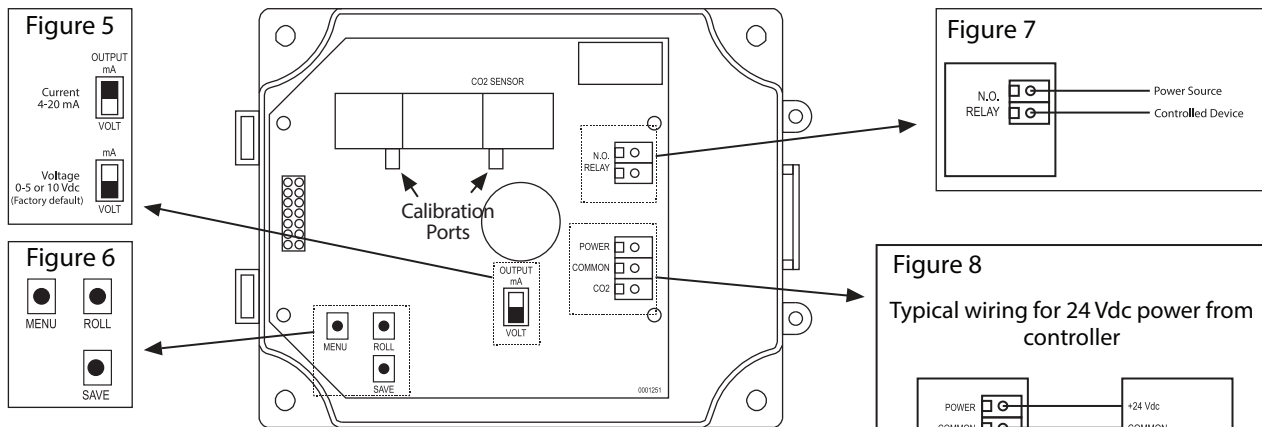

## Dimensions:

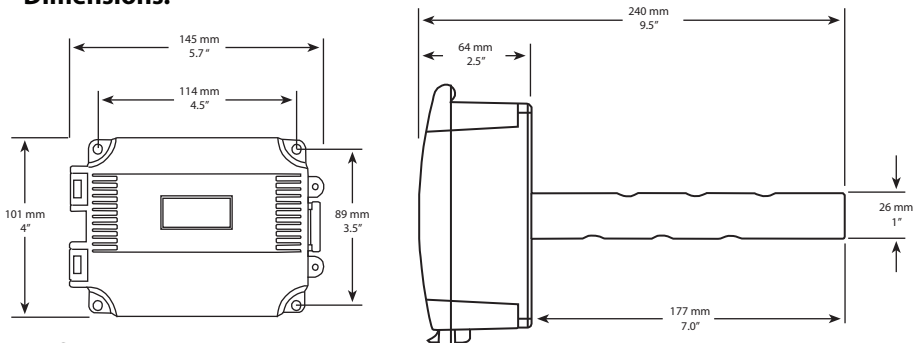

## Specification:

Range:.....400 - 2000 ppm  
 Accuracy:.....±30 PPM + 3% of reading with Auto Cal on.  
 Sensor:.....Non-Dispersive Infrared (NDIR), diffusion sampling  
 Temp. Dependence:.....0.2% FS per °C  
 Stability:.....< 2 % FS over life of sensor  
 Sensor Life Span:.....15 years typical  
 Press. Dependence:.....0.13% of reading per mm Hg  
 Altitude Correction:.....Programmable from 0-5000 ft via keypad  
 Response Time:.....<2 minutes for 90% step change typical  
 Warm-up Time:.....<2 minutes  
 Power Supply:.....20-28 Vac/dc (non-isolated half-wave rectified)  
 Output Signals:.....Default is 0-10 Vdc. 0-5 Vdc or 4-20 mA active (sourcing), are field selectable  
 Consumption:.....100 mA max @ 24 Vdc, 185 mA max @ 24 Vac (with all options)  
 Output Drive Capability:.....**Current:** 550 ohms max  
**Voltage:** 10K ohm min  
 Output Resolution:.....10 bit PWM  
 Protection Circuitry:.....Reverse voltage & overvoltage protected

Operation Conditions:.....32°-122°F (0°- 50°C), 0-95% RH non-condensing  
 Wiring Connections:.....Screw terminal block (14 to 22 AWG)  
 External Dimensions:.....**Enclosure:** 5.7" x 3.95" x 2.5" (145mm W x 100mm H x 63mm D)  
**Aspiration Probe:** 7" (177mm) long x 1" (25.4mm) dia  
 Enclosure Ratings:.....NEMA 4X (IP65)  
**LCD Display:**  
 Resolution:.....1 ppm CO2  
 Size:.....1.4" w x 0.6" h (35 mm x 15 mm)  
 Alpha-numeric 2 line x 8 character  
 Backlight:.....Enable or disable via keypad  
**Relay Output:**  
 Contact Ratings:.....Form A contact (N.O.), 2 Amps @ 140 Vac, 2 Amps @ 30 Vdc  
 Relay Trip Point:.....Programmable 500-1500 ppm  
 Relay Hysteresis:.....Programmable 25-200 ppm

### **Start-up**

Verify the device is properly wired and connections are tight. Ensure the V/I switch is set for the correct signal type. Apply power and the LCD will indicate the software version number, the output signal type, the relay setpoint, the CO2 measurement range and then the sensor will begin reading the CO2 level, output the correct analog signal and display the value on the LCD.

### **Output**

The CO2 output is scaled such that 4-20 mA, 0-5/0-10 Vdc equals 400 to Out\_High. The factory default is 400-2000 ppm. Out\_High can be changed in the Setup Menu and the output is scaled accordingly. The voltage output defaults to 0-10 Vdc (0-5 Vdc can be selected in the menu).

### **Operation**

The output signal is available on the CO2 terminal and is connected to the BAS analog input which reads the signal and calculates the CO2 ppm value using correct scaling for the range and signal type. The CO2 value is used to control output ventilation devices or initiate alarms. The CO2 value is also displayed locally on the LCD. The relay can control a small fan or alarm by setting the trip value and hysteresis to appropriate values.

### **Setup Menu**

The menu has several items shown below. Some items change depending on the hardware configuration and the CO2 sensor. To enter the menu, press and release the <MENU> key while in normal operation. This will enter SETUP menu step 1, pressing the <MENU> key again advances to step 2. Each press of <MENU> advances the menu item. No values are saved or changed by using <MENU>. The <ROLL> key is used to make changes to program variables by scrolling through the available options. When a value is changed, use the <SAVE> key to save it to memory and advance to the next menu item. See Figure 8.

<MENU> Press and release the <MENU> key to enter the SETUP menu.

#### **1. Output High**

Out High  
2000 ppm

The factory default is 2000 ppm. The default CO2 range is 400-2000 ppm. The span can be changed from 800 to 2000 ppm in increments of 100. Use the <ROLL> key to change the value and <SAVE> to save.

Press <MENU> to advance.

#### **2. Altitude Adjustment**

Altitude  
0 Ft

The default is 0 feet. Change by using the <ROLL> key from 0 to 5000 feet in 500 ft increments. Change for CO2 local altitude correction and press <SAVE> to save a change.

Press <MENU> to advance.

#### **3. Auto Calibration (ACLP)**

Auto Cal  
ON

Automatic Cal Mode default is ON to correct CO2 sensor drift to better than  $\pm 10$  ppm per year. Change ON with the <ROLL> key and save using <SAVE>. ON is recommended for applications where the CO2 level will be close to normal (400 ppm) at least once per day. If a building is occupied 24 hours and the CO2 level is fairly constant then this should be set to OFF. See ACLP Software section on page 4.

Press <MENU> to advance.

#### **4. Relay Setpoint**

Relay SP  
1000 PPM

The relay trip setpoint default is 1000 ppm. It can be changed from 500 to 1500 in 100 ppm increments 1000 ppm. Save changes by using the <SAVE> key.

Press <MENU> to advance.

#### **5. Relay Hysteresis**

Relay Hy  
50 PPM

The relay hysteresis default is 50 ppm. This can be changed from 25 to 200 in 25 ppm increments. Use <SAVE> to save any change.

Press <MENU> to advance.

#### **6. Relay Test**

Relay  
Test OFF

Use the <ROLL> key to toggle the relay ON or OFF for testing purposes. Press either <SAVE> or <MENU> to turn the relay off and advance to the next item.

Press <MENU> to advance.

Continued

## 7. Output Type

Out Type  
0-10 Vdc

For voltage, the factory default output type is 0-10 Vdc. Use the <ROLL> key to change the value to 0-5 Vdc if necessary. Press the <SAVE> key to save. If the switch is set to mA, then 4-20 mA is displayed.

## 8. Output Test

Output  
Test OFF

Press <MENU> to advance.

Use the <ROLL> key to toggle the output OFF (normal operation), MIN (minimum output) or MAX (maximum output) for testing purposes. Press either <SAVE> or <MENU> to set it back to OFF and advance to the next item.

## 9. Calibration

Calibrat  
1000 PPM

Press <MENU> to advance.

This item is used for 1000 ppm gas calibration and is explained in the Calibration section.

## 10. LCD Backlight

Backlite  
Enable

Press <MENU> to advance.

The factory default is Enable. Use the <ROLL> key to enable or disable the LCD backlight. When enabled the backlight is always on, when disabled it never lights. Press the <SAVE> key to save the setting.

Press <MENU> to advance.

## 12. Menu Exit

Menu  
Exit

Press <SAVE> to exit the menu and return to normal operation or <MENU> to repeat the menu.

### ACLP Software

ACLP (Automatic Calibration Logic Program) software utilizes the computing power in the sensor's on-board microprocessor to remember the lowest CO<sub>2</sub> concentration that takes place every 24 hours. The sensor assumes this low point is at outside levels. The sensor is also smart enough to discount periodic elevated readings that might occur if for example a space was used 24 hours per day over a few days. Once the sensor has collected 14 days worth of low concentration points, it performs a statistical analysis to see if there has been any small changes in the sensor reading over background levels that could be attributable to sensor drift. If the analysis concludes there is drift, a small correction factor is made to the sensor calibration to adjust for this change.

### Calibration

**The CO<sub>2</sub> transmitter comes factory calibrated, with no need for adjustment.** This section is provided to explain how to calibrate the device if the installation requires periodic calibration and/or testing.

Calibration with gas requires a field calibration kit with pressure regulator, necessary tubing and appropriate bottle of CO<sub>2</sub> gas. Note that the procedure depends on the device model. The standard model requires only a single point 1000 ppm calibration to meet specified accuracy due to the Automatic Calibration mode and other technology incorporated into the CO<sub>2</sub> transmitter.

#### 1000 PPM Calibration

Connect the 1000 ppm CO<sub>2</sub> gas bottle and apply the gas. The CO<sub>2</sub> reading on the LCD will begin to approach 1000 ppm. Wait 1 to 2 minutes until the CO<sub>2</sub> reading stabilizes.

Enter the Setup menu and use the <MENU> key to advance to Calibrat 1000 PPM. Press and hold the <SAVE> key for 2 seconds and the display will change to Waiting Calibrat then to Waiting 5 minute to indicate that the device is calibrating. Again, this process takes about 5 minutes. When calibration is complete the unit will display the ppm and Cal Done. Press the <SAVE> key to return to normal operation and shut the gas off.

Disconnect the tubing and replace the cap on the sensor chamber as calibration is complete.